

# Pro lite

## Features List

- Large 2.4m workspace
- Three 3u top racks and capabilities for integration of bottom 12u racks
- Deep monitor bridge to house Grade 1 and screen monitors
- Available in Crown Oak (as shown) and Crown Maple veneer
- Complete cable management system



**ELEVATIONS**

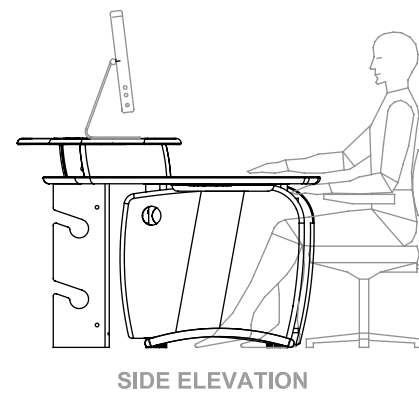
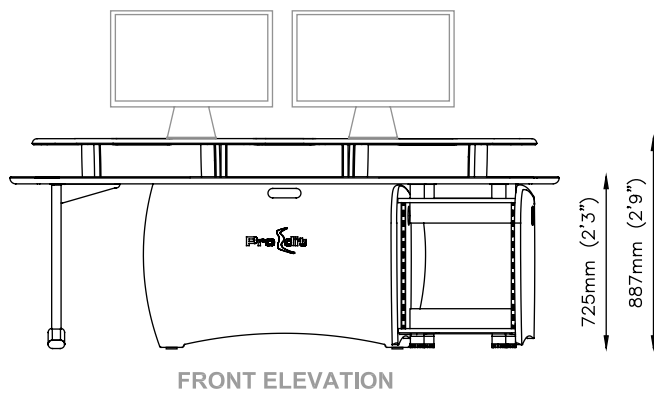
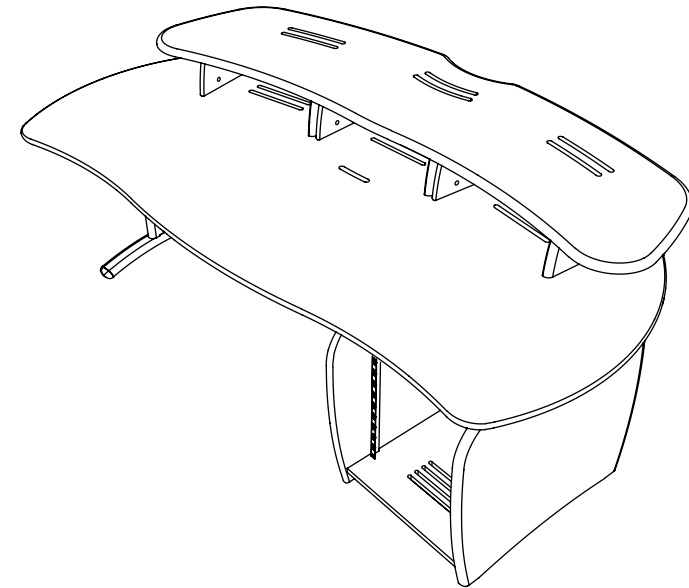
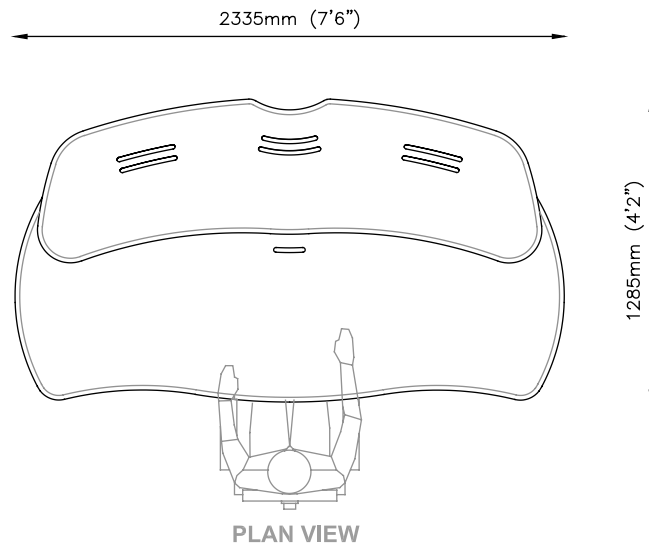

# CONFIGURATIONS

The ProLite desk is similar to the ProEdit as it is designed for offline and online editing environments. The ProLite is not part of the ProWave range and cannot be integrated with the ProWave racks or worktops, however the ProLite does have it's own 12u rack as an optional extra.

This product range comes flat packed which makes it easy to ship and assemble on site. We offer a *free design* layout service so if you send us a floor plan of your studio, we will fit your ProLite desk into the space. We also offer *Hybrid* with our product range; this means custom sections can be built if required for a specific project.

The standard colours are Crown Maple and Crown Oak.

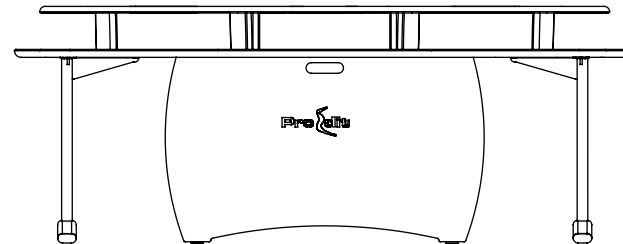
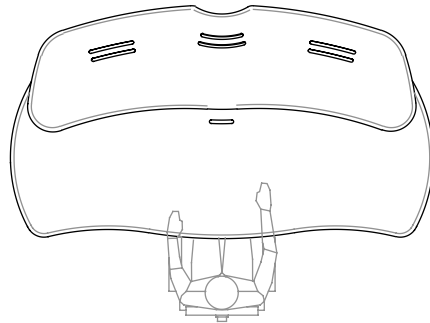

**ProLite**

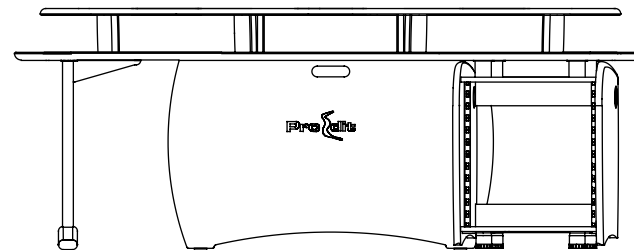
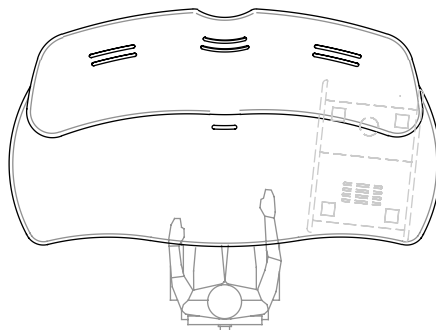

**ProLite + 12u rack**